

MINIPIX *TPX3*

Datasheet

Model No.: MNXT3S-Xxx190411
MNXT3S-Xxx190925
MNXT3S-Xxx220520



General features

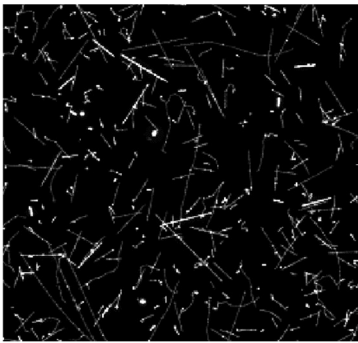

Illustration of particle tracking capability of Timepix3 device: The tracks of different particles of radiation background were recorded during 10 minutes in office space in Prague. Brightness corresponds to energy. No noise (clean zero) is seen in dark regions. All basic particle track types are seen nicely: muons = straight lines, alpha particles = bright balls, electrons = curved lines, gamma and X-rays = dots and blobs.

The **MINIPIX TPX3** is a miniaturized and low power radiation camera equipped with particle tracking and imaging detector Timepix3 (256 x 256 square pixels with pitch of 55 μm). Several sensor materials are provided according to customer preference (usually 300 μm thick silicon).

The Timepix3 detector is position, energy and time sensitive: For each ionizing particle (e.g. X-ray photon) it digitally registers its position, energy, time of arrival and track shape - basically all information you could want. The other measures can be calculated from the track shape (particle type, direction of flight, LET, charge...). The information on each detected particle is either read out immediately (pixel mode) at maximal rate of 2,3 million hit pixels per second or accumulated in images (frame mode) and read out later at maximal speed of 16 frames per second.

The typical and intended applications of **MINIPIX TPX3** are:

- **Spectral X-ray imaging:** XRF imaging, X-ray radiography (low flux).
- **Energy dispersive XRD, SAXS or WAXS:** Monochromatic X-ray source is NOT needed! Even high energy for thick samples is possible (e.g. 100 keV)!
- **Spectral gamma ray imaging:** Scintigraphy or SPECT, radiography with isotopes.
- **Radiation monitor¹:** Particle type sorting, spectroscopy, directional sensitivity ...
- **Gamma camera:** Special shielded box and collimators are available upon request.
- **Compton camera:** Gamma ray imaging based on Compton scattering (special software module for image reconstruction is required).

The **MINIPIX TPX3** device is controlled via USB 2.0 interface with standard μUSB connector. Complex PIXet Pro software for detector operation is provided together with the device. All major operating systems are supported (MS Windows, Mac OS and LINUX). Extra software modules are available for special functions (e.g. spectrum filtering and reconstruction, coded aperture image reconstruction, Compton camera image and spectrum reconstruction, radiation field decomposition, networking of many devices ...).

Main features

- Readout chip type..... Timepix3
- Pixel size² 55 x 55 μm
- Sensor resolution 256 x 256 pixels
- Time resolution 1,6 ns
- Dynamic range in one frame³ 1022
- Sensor material 100, 300 or 500 μm Si, 1 mm CdTe
- Dark current none
- Interface USB 2.0 (High-Speed)
- Maximum readout speed 2,35 million pixels / s
- Dimensions 80 x 21 x 14 mm
- Weight 40 g

¹ **MINIPIX TPX3** is not a certified dosimetric device. It serves as the first level indicator and monitor of radiation fields allowing identification of radiation type. Radiation protection of people cannot be based on measurements of **MINIPIX TPX3**.
² 55 x 110 μm at the edges and 110 x 110 μm at the corners
³ i.e., counter depth. Dynamic range of integrated picture is theoretically unlimited.

Device parameters

Operating conditions

Symbol	Parameter	Value	Units	Comment
T _a	Operating ambient temperature range ¹	0-50	°C	
Φ	Humidity	< 85	%	Not condensing
IP	IP rating with cover	IP40		
IP	IP rating without cover	IP10		

¹ With temperature stabilization – see the paragraph below.

Vacuum operation

Advacam detectors can be vacuum compatible on request. Contact support@advacam.cz for more information.



- In case of vacuum operation, operate only with air pressure lower than 10⁻³ Pa.
- Intended for dust free indoor use.
- Make sure to disconnect the device from power during pumping down or venting the vacuum chamber!
- The device will automatically shut down after chip or CPU temperature exceeds 55 °C.
- A direct connection to the host device is required for maximum performance. Connecting via a USB hub may negatively affect the performance and stability of the device.

External temperature stabilization

Temperature stabilization of the device required. Attach the back of the device to a water-cooled plate or to a Peltier module. The temperature should be set to 22 °C.

Electrical specification

T_{dev} = 22 °C, USB voltage V_{cc} = 4,8 V

Symbol	Parameter	Min	Typ.	Max	Units	Comment
V _{cc}	Supply voltage	4,0	5,0	5,5	V	Comply with USB 2.0
I _{cc}	Supply current		300	500	mA	Comply with USB 2.0, Mode dependent
P1	Power dissipation		2,5		W	

Typical bias voltage source for sensor diode	Si				CdTe		Units
	100	300	500	1000 ¹	1000	2000 ¹	
Thickness	100	300	500	1000 ¹	1000	2000 ¹	μm
V _{BIAS} ²	50	150	150	200	-300 to -500	-500	V

¹ Customized product

² Positive for Si sensors, negative for CdTe. Typical values



Performance characteristics

Symbol	Parameter	Min	Typ.	Max	Units	Comment
f_f	Frame-rate			16	fps	with USB 2.0 Host
T_{FREAD}	Frame readout time	62			ms	
f_p	Pixel type hit-rate in ToT+ToA mode (pixels per second)			$2,35 \times 10^6$	pps	with USB 2.0 Host

Pixel mode hit-rate measurement

The whole detector is exposed to homogenous direct (perpendicular) irradiation from X-ray tube operated at 18 kVp with 2 mm Aluminum filter. The measurement type is set to “Pixels” and mode to “ToT+ToA”, all other parameters are set to factory defaults (as stored in configuration file delivered with the device). The exposure time is set to 0,1 s. The “Clustering” tool of PIXet Pro is used to analyze measured data. The number of hit pixels per second is drawn as function of X-ray tube current searching for saturation.

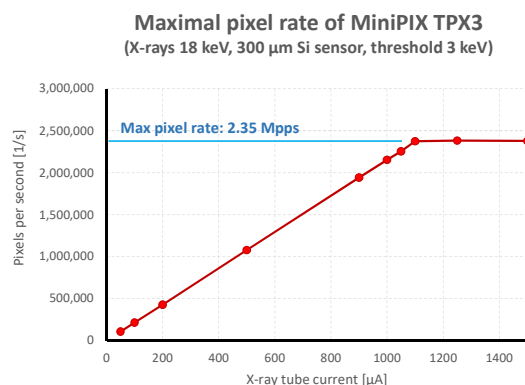

Sensor parameters

$T_{\text{dev}} = 22 \text{ }^\circ\text{C}$

Parameter	Si				CdTe		Units	Comment
	100	300	500	1000 ¹	1000	2000 ¹		
Thickness	100	300	500	1000 ¹	1000	2000 ¹	μm	
Calibrated energy threshold ²	3,0	3,0	3,0	3,0	5,0	5,0	keV	
Energy resolution in ToT mode (σ @ 60 keV)	1,2 – 2,6	1,3 – 2,7	1,4 – 3,5	1,7 – 3,6	2,8 – 5,4	2,9 – 8,3	keV	Valid for the standard calibration
Energy resolution in ToT mode (σ @ 122 keV)					3,4 – 6,0	4,5 – 9,9	keV	Valid for the standard calibration
Typical detectable energy range for X-rays	3 – 60				5 – 500		keV	See chart below
Good pixels	> 99,5 %				> 99,5 %			
Pixel size ³	55 x 55						μm	

¹ Customized product

² Premium calibration and/or chip class can achieve even better performance. For more information, please contact support@advacam.cz

³ 55 x 110 μm at the edges and 110 x 110 μm at the corners

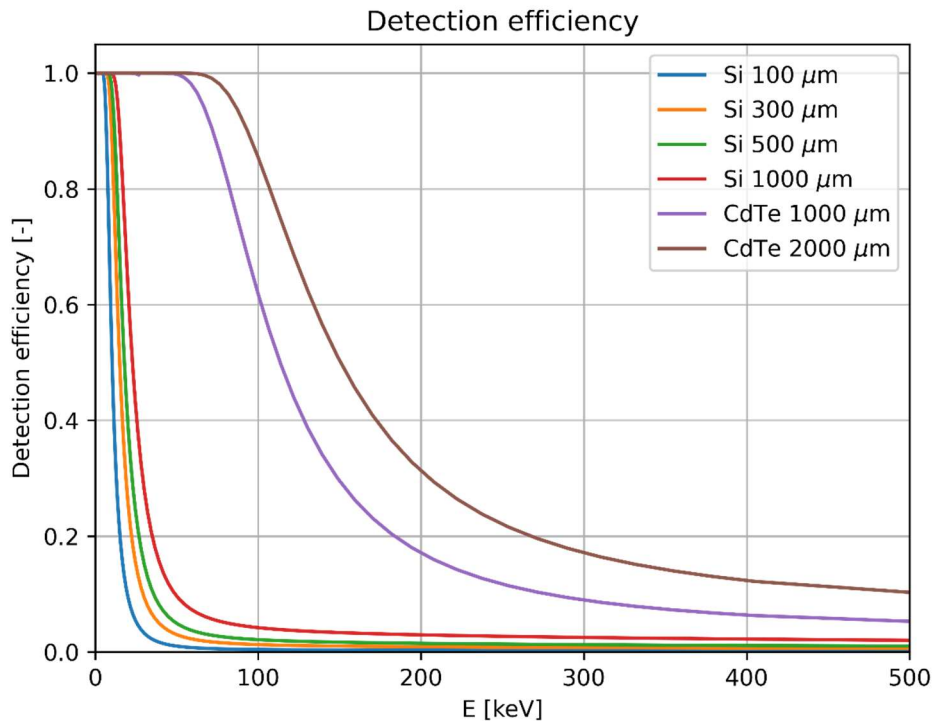

Basic principles, measurement types and operational modes

The ionizing radiation particle interacts with the sensor material creating an electric charge. This charge is collected by electric field and brought to pixel preamplifier where it is amplified and shaped forming triangular voltage pulse. The amplitude and duration of this pulse is proportional to energy deposited by particle within the pixel. The situation when the voltage pulse amplitude in particular pixel exceeds preselected threshold value is called “event” or “hit”.

Each pixel contains three digital counters (10, 14 and 4 bits). These counters are used differently according to measurement type and mode. There are four different quantities which can be measured and stored in counters of each pixel – these are selected by operational modes.

Operational modes:

Number of events = number of events (hits) in the pixel during exposure time (this mode is suitable mainly for frame type readout).

Time-over-Threshold (ToT) = number of periods of 40 MHz clock signal (25 ns step) when amplifier output signal stays over the energy threshold. The ToT can be transformed to energy in keV using per-pixel-calibration function. The coefficients for per-pixel-calibration are unique for each pixel and they are stored in configuration file delivered with the device. The energy calibration is valid only for given values of other detector parameters as delivered in configuration file (especially threshold).



Time-of-Arrival (ToA) = number of periods of 40 MHz clock signal (25 ns step) from start of exposure till the event is registered by pixel (i.e. pulse in pixel crosses the threshold). The range is 409,6 μ s. Additional 16 bits are added in FPGA in readout electronics so that the total range is 26,8 seconds. An additional counter has also been added to perform scans beyond 26,8 seconds.

Fast-Time-of-Arrival (FToA) = time difference between event detection and next clock signal measured with step of 1,5625 ns. Range is 4 bits. The combination of ToA and FToA gives precise time of event detection in nanoseconds using following formula:

$$\text{Time [ns]} = \text{ToA} * 25 - \text{FToA} * 1,5625$$

Measurement types:

Frame type measurement No data is sent out of device during the exposure time. All measured events are accumulated in counters of pixels. **Event counter** is incremented and ToT is integrated in to **iToT counter** for all events. The measured data is read-out after end of exposure time for all pixels with nonzero content. No measurement can be performed during readout process. Measurement types in PIXet Pro: Frames, Integral.

Pixel type measurement Information about all hit pixels is read-out immediately and continuously during exposure time. If hit rate is below maximal value (see f_p in table of Performance characteristics) then there is practically no deadtime. Measurement type in PIXet Pro: Pixels.

Sometimes this mode is referred to as the data-driven mode or the event-based mode.

Combinations of operation modes and measurement types (rarely used cases are shown with gray background):

Type	Mode	Range	Description
Frames (reading all pixels after end of exposure)	ToA+ToT	18 bit + 10 bit	2 output frames per exposure: ToA = Time of Arrival of first event in pixel, ToA and FToA ¹ combined ToT = Time over Threshold, i.e. energy in keV if calibration is loaded and switched on
	ToA	18 bit	1 output frame: ToA = Time of Arrival of first event in pixel, ToA and FToA ¹ combined
	Event+iToT	10 bit + 14 bit	2 output frames per exposure: Events = number of events in pixel iToT = integrated Time over Threshold, i.e. energy in keV if calibration is loaded and switched on, for all events in pixel
Pixels (reading only hit pixels continuously during exposure)	ToA+ToT	18 bit + 10 bit	Data stream contains 4 values per pixel per event: Position, ToT, ToA and FToA ¹ (for data formats .t3*)
	ToA	18 bit	Data stream contains 3 values per pixel per event: Position, ToA and FToA ¹ (for data formats .t3*)
	Only ToT	10 bit	Data stream contains 2 values per pixel per event: Position and ToT (for data formats .t3*)

¹ ToA and FToA are combined together by software automatically. For Pixel type measurement, if saved as a .t3pa file, ToA and FToA are stored as separate items.



Device description

The device is delivered with USB flash disk containing installer of PIXet Pro software, unique device configuration and calibration file and protocol on quality tests.

The device casing is made of aluminum with sliding cover made of stainless steel protecting the sensor window. The communication and powering is provided by USB 2.0 Micro-B connector and cable.



USB connector

USB type Micro-B, Standard USB 2.0 High-Speed. The USB cable length should be less than 2 m. For longer connections, a repeater or active cable is suggested.

Mechanical dimensions

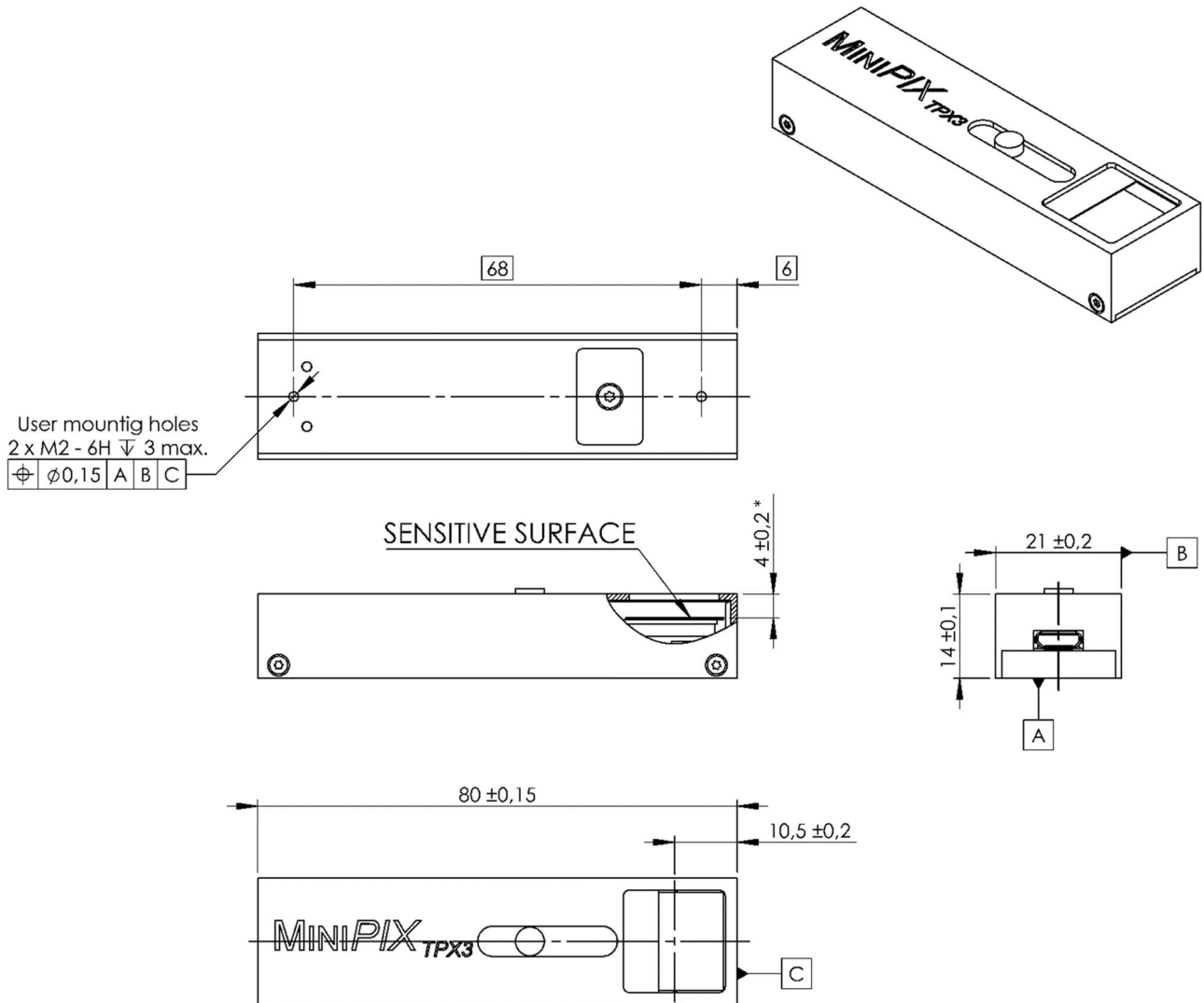

All dimensions are in mm.

* Sensitive surface distance from top of the box is stated for 300 μ m sensor thickness.



Extreme care must be taken when removing protecting cover and handling the **MINIPIX TPX3** without the protecting cover. Warranty does not apply to mechanical damage of the sensor and wirebonds.

Model number codes

Example:

MNX T3S - X P 3 XXXXXXXXXX

Device name:

MNX – MiniPIX

Device modification:

T3S – Timepix3 Standard

Sensor type:

P – Planar silicon

C – CdTe

Sensor thickness:

1 – 100 μm

3 – 300 μm

5 – 500 μm

A – 1000 μm

B – 2000 μm

Device build version:



Instructions for safe use



Do not touch the sensor surface!

To avoid malfunction or damage to your **MINIPIX TPX3** please observe the following:

- Do not expose to water or moisture.
- Do not disassemble. Wire-bonding connection may be irreversibly damaged.
- Do not insert any object into the sensor window.
- The maximum USB cable length is 2 m.
- Thermal stabilization of the device is necessary. Recommended temperature is 22 °C.
- A direct connection to the host device is required for maximum performance. Connecting via a USB hub may negatively affect the performance and stability of the device.
- The protection provided by this product may be impaired if it is used in a manner not described in this document.

Disposal



Do not dispose these instruments as unsorted municipal waste. Please use separate collection facility to contact the supplier from which the instrument was purchased. Please make sure discarded electrical waste is properly recycled to reduce environment impact.

Release history

Date (YY/MM/DD)	Changes	Changed by
19/04/12	Preliminary datasheet	
20/04/03	New version; Mechanical dimensions; Sensor parameters	
22/05/25	New version; Vacuum compatibility; Sensor parameters; ToA	
22/08/15	New version; new components	
24/03/27	Datasheet revision	J. Baborák
24/04/09	Measurement types	J. Baborák, D. Doubravová
24/05/24	New graphic style of the document	J. Baborák, P. Bloudek
24/06/07	Warning sign change	J. Baborák
24/06/12	Temperature stabilization instructions edited	J. Baborák
24/06/24	USB hub warning added	J. Baborák
24/07/23	Minor format changes	J. Baborák

Copyright ©

ADVACAM s.r.o.

U Pergamenky 12

Prague 170 00

Czech Republic

Tel.: +420 608 605 533

Email: info@advacam.com

www.advacam.com

