

---

# MINIPIX

## SPRINTER

Preliminary Datasheet

---

Model No.: MNXT2S-Xxx



## General features

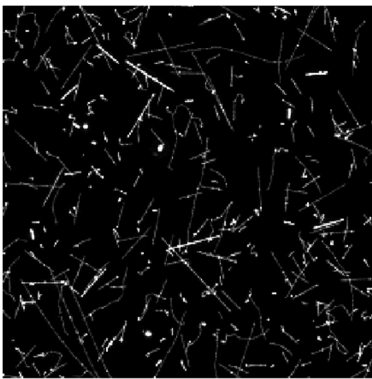

Illustration of single particle sensitivity of Timepix2 detector. The tracks of different particles of radiation background (mostly muons and few protons) were recorded in 5 minutes on board of an airplane. No noise (clean zero) is seen in the dark regions.

The **MINIPIX**<sub>SPRINTER</sub> is a miniaturized and low-power radiation camera solution that incorporates a single Timepix2 detector with a sensor of customer preference (typically 300  $\mu\text{m}$  thick silicon). The detector features 256 x 256 pixels with a pitch of 55  $\mu\text{m}$  and is capable of single particle counting or high-energetic particle tracking for space applications<sup>1</sup>. This energy-sensitive detector also brings a new dimension to radiographic images. The **MINIPIX**<sub>SPRINTER</sub> device utilizes a USB 2.0 interface, allowing for reading of up to 99 frames per second. The signal-to-noise ratio exceeding 1000 enables crystal-clear X-ray images with low noise<sup>2</sup>.

The **MINIPIX**<sub>SPRINTER</sub> device controlled via a USB interface is compatible with major operating systems: MS Windows, Mac OS and Linux. The software *Pixet Pro* for detector operation, offering comprehensive functionality and ease of use, is supplied with the device. With its miniaturized size, low power consumption, and advanced Timepix2 detector technology, the **MINIPIX**<sub>SPRINTER</sub> is an efficient and effective solution for various radiation detection applications (imaging, XRD, XRF, particle tracking, space radiation monitoring, electron microscopy, science, education, etc.).

## Main Features

- Readout chip type ..... Timepix2
- Pixel size ..... 55 x 55  $\mu\text{m}$ \*
- Sensor resolution ..... 256 x 256 pixels
- Counter bit depth ..... 10/ 14 bit
- Sensor material ..... 100, 300, 500  $\mu\text{m}$  Si
- Dark current ..... none
- Interface ..... USB 2.0 (High Speed)
- Maximum frame rate ..... up to 99 fps
- Dimensions ..... 80 x 21 x 14 mm
- Weight ..... 37 g

\* 55 x 110  $\mu\text{m}$  at the edges and 110 x 110  $\mu\text{m}$  at the corners

<sup>1</sup> The device is not certified dosimeter. It serves as the first level indicator and monitor of radiation fields allowing identification of a radiation type. Radiation protection of people cannot be based on measurements with this device.

<sup>2</sup> Dynamic range of final picture is theoretically unlimited; the only limiting factor is exposure time.

## Device parameters

### Operating conditions

Symbol	Parameter	Value	Units	Comment
T <sub>a</sub>	Operating ambient temperature range <sup>1</sup>	0-50	°C	
Φ	Humidity	< 80	%	Not condensing
IP	IP rating with cover	IP40		
IP	IP rating without cover	IP10		

<sup>1</sup> With temperature stabilization – see the paragraph below.

### Vacuum operation

Advacam detectors can be vacuum compatible on request. Contact [support@advacam.cz](mailto:support@advacam.cz) for more information.



Operate only with air pressure lower than 10<sup>-3</sup> Pa. Intended for dust free indoor use. Make sure to disconnect the device from power during pumping down or venting the vacuum chamber!

### External temperature stabilization

Temperature stabilization of the device is strongly recommended for consistent results. Attaching a Peltier cooling or cooling plate at the back of the detector should serve the purpose. The temperature should be set to 22°C.



The device will automatically shut down after chip or CPU temperature exceeds 55°C.

### Electrical specification

T<sub>dev</sub> = 22°C, USB voltage V<sub>CC</sub> = 4.8V

Symbol	Parameter	Min	Typ	Max	Units	Comment
V <sub>CC</sub>	Supply voltage	4.5	5.0	5.25	V	
I <sub>CC2</sub>	Chip active		550	1000 *	mA	
P1	Power consumption		2.75	5	W	
V <sub>BIAS</sub>	Bias voltage for sensor diode	5	150	200	V	Depends on sensor thickness

\* Tentative

### Sensor parameters

T<sub>dev</sub> = 22°C

Symbol	Parameter	Si			Units	Comment
		100	300	500		
	Sensor thickness	100	300	500	μm	
σ	Energy resolution of energy discrimination threshold (σ @ 8 keV)	0.4 <sup>1</sup>			keV	
	Minimum energy threshold	5			keV	
σ	Energy resolution in full spectral mode (σ @ 8 keV)	0.9 <sup>1</sup>			keV	
σ	Energy resolution in full spectral mode (σ @ 23 keV)	1.3 <sup>1</sup>			keV	
σ	Energy resolution in full spectral mode (σ @ 60 keV)	2.0 <sup>1</sup>			keV	

	Typical detectable energy range for X-rays	5 to 60	keV	See chart below
	Pixel size <sup>2</sup>	55	μm	

<sup>1</sup> Typical values

<sup>2</sup> 55 x 110 μm at the edges and 110 x 110 μm at the corners

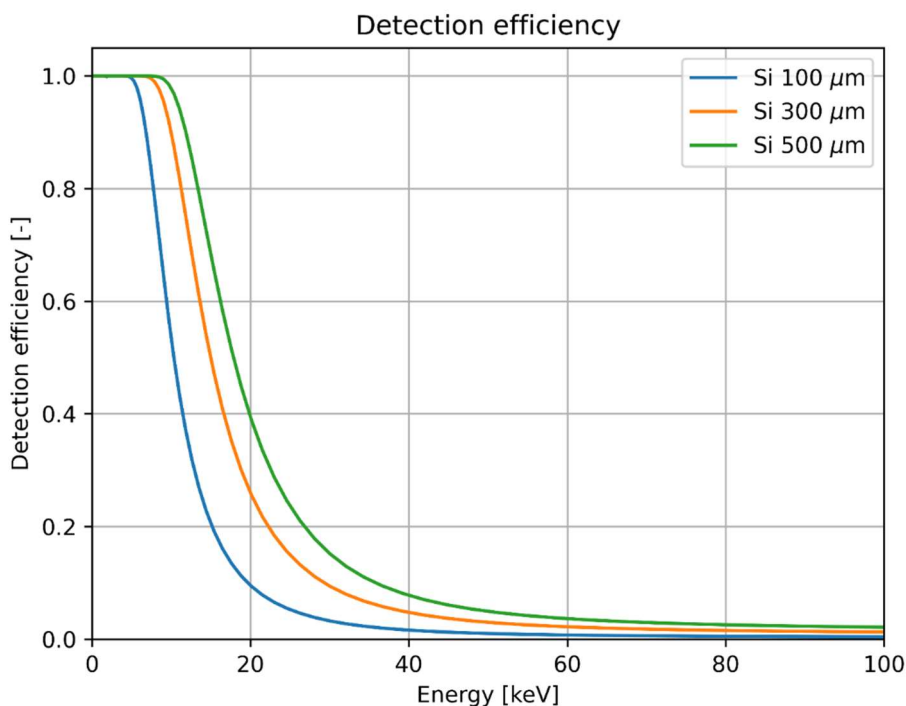

## Modes and types of readout chip operation

The detector is frame-based, i.e. the data from all the pixels are read out after the acquisition time is over.

### Counter bit depth

Different counter depths can be chosen for certain measurement modes. This enables tailoring the performance for higher frame rates, or better resolution.

An overview of operation modes (default cases are highlighted) together with maximum achievable frame rates is presented in the table below. Actual frame rate might decrease due to detected particle flux, software or processing being run simultaneously with the measurement, saving the data during the measurement, performance of the computer itself.



Mode	Counter Depth	Maximum frame rate
Counts	<b>14 bits</b>	64 fps
	10 bits - high frame rate	99 fps
Energy	<b>14 bits</b>	65 fps

## Device description



### USB connector

USB type Micro-B, Standard USB 2.0 High-Speed. The USB cable length should be less than 2m. For longer connections, a repeater or active cable is suggested.

### Mechanical dimensions

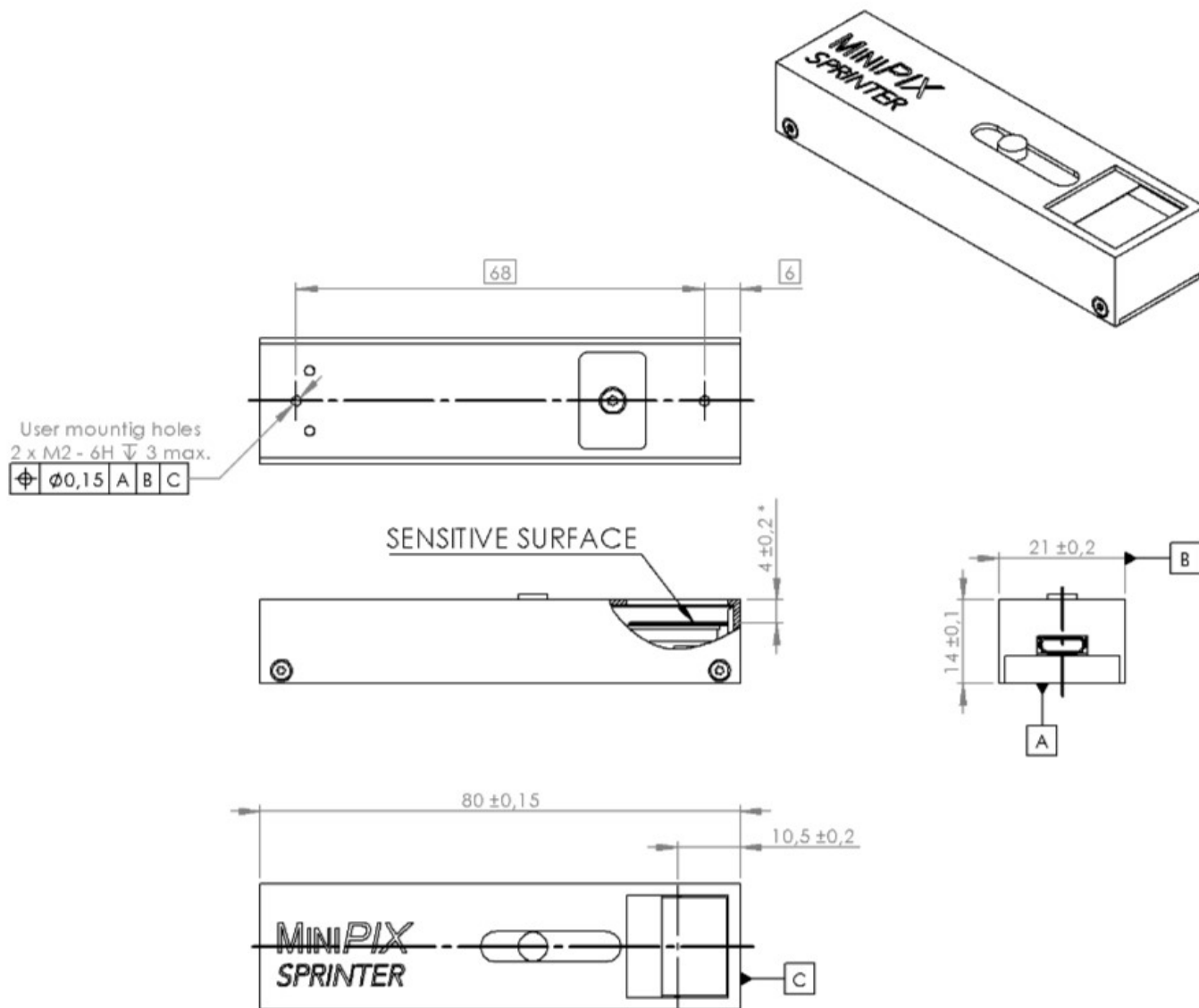

All dimensions are in mm.

\* Sensitive surface distance from top of the box is for 300  $\mu$ m sensor thickness.

Extreme care must be taken when removing protecting cover and handling the MINIPIX SPRINTER without the protecting cover. The warranty does not apply to mechanical damage of the sensor and wirebonds.



## Model number codes

Example: MNX T2S - X P 3 23110016

**Device name:**

MNX – MiniPIX

**Device modification:**

T2S – Timepix2 Standard

**Sensor type:**

P – Planar silicon

**Sensor thickness:**

1 – 100 μm

3 – 300 μm

5 – 500 μm

**Device build version:**

XXXXXXXX



## Instructions for safe use



**Do not touch the sensor surface!**

To avoid malfunction or damage to your **MINIPIX** *SPRINTER* please observe the following:

- Do not expose to water or moisture.
- Do not disassemble. Wire-bonding connection may be irreversibly damaged.
- Do not insert any object into the sensor window.
- The maximum USB cable length is 2 m.
- The protection provided by this product may be impaired if it is used in a manner not described in this document.
- Thermal stabilization of the device is necessary. Recommended temperature is 22 °C.

## Disposal



Do not dispose these instruments as unsorted municipal waste. Please use separate collection facility to contact the supplier from which the instrument was purchased. Please make sure discarded electrical waste is properly recycled to reduce environment impact.

## Copyright

ADVACAM s.r.o.

U Pergamenky 1145/12

170 00 Praha

Czech Republic





## Release history

Date (YY/MM/DD)	Changes	Changed by
23/04/25	First draft (MNXT2S-Xxx211214)	
23/11/28	Preliminary datasheet (MNXT2S-Xxx)	D. Doubravová
24/04/15	Datasheet revision – SPRINTER case	J. Baborák

PRELIMINARY

