

---

# ADVAPIX TPX3

## Datasheet

---

Model No.: APXMD3-Xxx170704  
APXT3M-Xxx180119  
APXT3M-Xxx200128  
APXT3M-Xxx201030



## General features

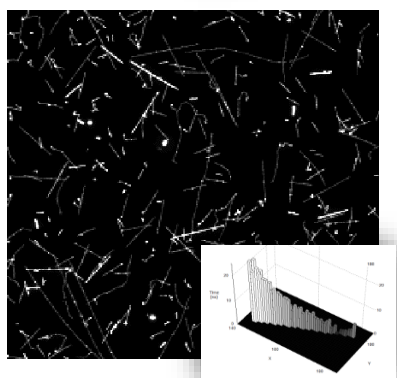

Illustration of single particle sensitivity of Timepix3 device. The tracks of different particles of radiation background (mostly muons and few protons) were recorded in 5 minutes on board of airplane. No noise (clean zero) is seen in dark regions. Inset shows the time profile along one muon track.

The **ADVAPIX TPX3** modules were designed with special emphasis to performance and versatility which is often required in a scientific experimental work. They contain CERN detector Timepix3 for particle tracking and imaging with Si or CdTe sensor. The **ADVAPIX TPX3** modules can be used in different configurations: telescope of several layers for better particle tracking and/or side-by-side for larger area coverage. Each module contains one Timepix3 device with fast sparse data readout to acquire up to 40 Mhits per second. A separate USB 3.0 channel for each module assures fast read-out of the whole modular system. The sensor type and thickness is of customer's choice.

The typical and intended applications of **ADVAPIX TPX3** include:

- **Spectral X-ray and gamma ray imaging:** X-ray fluorescence imaging, X-ray radiography (low flux), scintigraphy or SPECT, radiography with isotopes.
- **Energy dispersive XRD, SAXS or WAXS:** Monochromatic X-ray source is NOT needed! Even high energy for thick samples is possible (e.g. 100 keV)!
- **Particle tracking and ion beam monitoring:** detectors can be used for tracking and tagging of primary particles (e.g. ions) as well as secondary radiation (spallation, fragmentation, recoiled, bremsstrahlung, prompt/delayed decays, neutrons<sup>1</sup> ...).
- **Neutron imaging:** The sensors can be adapted for neutron imaging by deposition of converter layers<sup>1</sup>.

Recording shapes of individual hits together with advanced data processing allows increasing the spatial resolution in some applications to units of microns or even sub-micrometric level (for ions).

## Main Features

- Readout chip type ..... Timepix3
- Pixel size ..... 55 x 55 μm\*
- Sensor resolution ..... 256 x 256 pixels
- Time resolution ..... 1.6 ns
- Power ..... External or via second USB 3.0
- Interface ..... USB 3.0 (Super-Speed)
- Maximum readout speed ..... 40 million pixels / s
- Dimensions ..... 125 x 79 x 25.5 mm
- Weight ..... 503 g

<sup>1</sup> Convertors based on <sup>6</sup>LiF or <sup>10</sup>B<sub>4</sub>C for slow neutrons (efficiency up to 4%) or PE for fast neutrons.  
\* 55 x 110 μm at the edges and 110 x 110 μm at the corners



## Device parameters

### Operating conditions

Symbol	Parameter	Value	Units	Comment
TA	Ambient Temperature Range	0-50	°C	
Φ	Humidity	<80	%	Not condensing
	Altitude*	<2000	m	Above sea level
IP	IP rating	IP40		With cover

**Warning:** Disconnect the device from power during pumping down or venting the vacuum chamber!

### Electrical Specification

T<sub>A</sub> = 25°C, USB voltage V<sub>CC</sub> = 4.8V

Symbol	Parameter	Min	Typ	Max	Units	Comment
V <sub>CC</sub>	Supply Voltage	4.0	5.0	5.5	V	
I <sub>CC</sub>	Supply Current					
I <sub>CC1</sub>	Chip active		800	1500	mA	
P1	Power Dissipation			7.5	W	
<b>I/O Conn. Input CMOS 2.5V</b>						
V <sub>INL</sub>	Voltage Low	-0.3		0.7	V	
V <sub>INH</sub>	Voltage High	1.7		2.8	V	
<b>I/O Conn. Input LVDS</b>						
V <sub>IN</sub>	Voltage Range	0		2.5	V	
V <sub>INDIFF</sub>	Differential Voltage	250		600	mV	
<b>I/O Conn. +5V (pin 2)</b>						
I <sub>MAX</sub>	Maximum current	0		0.5	A	
V <sub>+5V</sub>	Pin Voltage		4.5		V	V <sub>CC</sub> – 0.5V
<b>Bias Voltage Source for Sensor Diode</b>						
V <sub>BIAS</sub>	Bias Voltage	0		±450	V	Polarity is sensor dependent

### Performance characteristics of Timepix3

Symbol	Parameter	Min	Typ	Max	Units	Comment
f	Hit-rate			40	MPixels/s	with USB 3.0 cable
	Data rate			2.4	Gbit/s	with USB 3.0 cable
TREAD	Frame Readout Time <sup>2</sup>		33		ms	with USB 3.0 cable
dT	Time resolution	1.56			ns	
FREAD	Read-out frequency		320		MHz	½ of maximum ROC freq

<sup>2</sup> During Readout time (or Dead time), no signal is collected from the sensor.

### Pixel mode hit-rate measurement

The whole detector is exposed to homogenous perpendicular irradiation from X-ray tube operated at 30 kVp with 3 mm Aluminum filter. The measurement type is set to “Pixels” and mode to “ToT+ToA” The following setting must be set before the measurement starts. Unchecked the “ProcessData” and “DummyAcqNegativePolarity” and set value 400 to the field DDBlockSize and value 1000 to the field DDBuffSize in the tab Readout in More Detector Setting dialog which is accessible from the main Pixet window on the right side under the panel Detector setting. All other parameters are set to factory defaults (as stored in the configuration file delivered with the device). The exposure time is set to 1 s. The data must be read out to the memory. The data are saved to disk after the measurement and later processed. The “Clustering” tool of PiXet-Pro is used to analyze measured data where you can replay the data and find the total number of hit pixels. For more information inquire the attachment “Hit rate AdvaPIX TPX3”

The number of hit pixels per second is drawn as a function of X-ray tube current searching for saturation. The number of hit pixels per second is drawn as function of X-ray tube current searching for saturation.

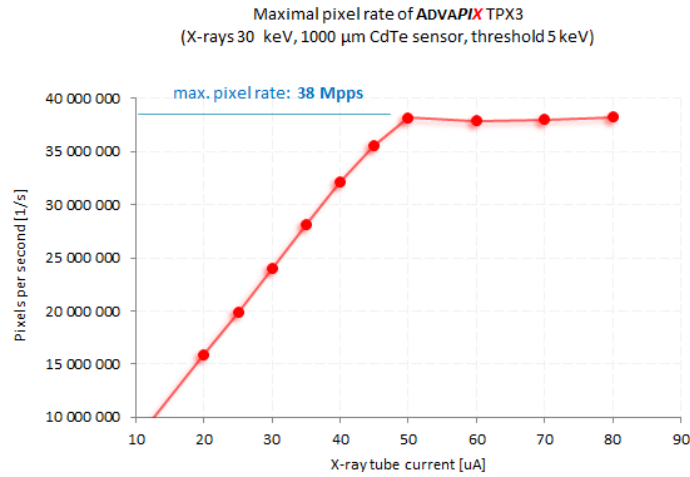

### Sensor parameters

T<sub>A</sub> = 25°C

Symbol	Parameter	Si				CdTe		Units	Comment
		100	300	500	1000	1000	2000		
	Thickness	100	300	500	1000	1000	2000	µm	
	Minimum energy threshold	2.0 - 2.7	2.0 - 2.7	2.0 - 3.0	2.0 - 3.0	2.5 - 4.5	3.0 - 5.0	keV	
σ <sub>Thl@60</sub>	Energy resolution in ToT mode (σ @ 60 keV)	1.2 - 2.6	1.3 - 2.7	1.4 - 3.5	1.7 - 3.6	2.8 - 5.4	2.9 - 8.3	keV	
σ <sub>Thl@122</sub>	Energy resolution in ToT mode (σ @ 122 keV)					3.4 - 6.0	4.5 - 9.9	keV	
	Typical detectable energy range for X-rays	2.0 - 60				2.5 - 500		keV	See chart below
	Pixel size	55						µm	



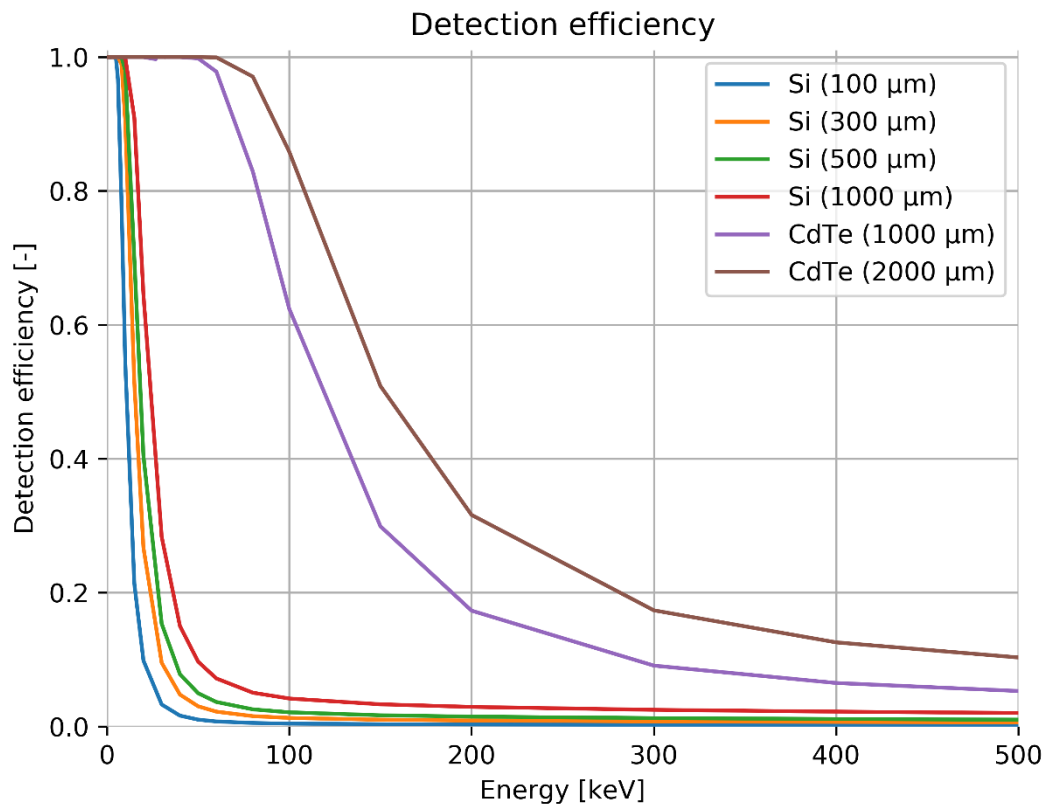

## Basic principles, measurement types and modes

The ionizing radiation particle interacts with the sensor material creating an electric charge. This charge is collected by electric field and brought to pixel preamplifier where it is amplified and shaped forming triangular voltage pulse. The amplitude and duration of this pulse is proportional to energy deposited by particle within the pixel. The situation when the voltage pulse amplitude in particular pixel exceeds preselected threshold value is called “event” or “hit”.

Each pixel contains three digital counters (10, 14 and 4 bits). These counters are used differently according to measurement type and mode. There are four basic values which can be measured and stored in counters of each pixel:

### Measurement modes:

**Number of Events** = number of events (hits) in the pixel during exposure time (this mode is suitable mainly for frame type readout).

**Time-over-Threshold (ToT)** = measured as number of periods of 40 MHz clock signal (25 ns step) when amplifier output signal stays over the energy threshold. The ToT can be transformed to energy in keV using per-pixel-calibration function. The coefficients for per-pixel-calibration are unique for each detector pixel and they are stored in configuration file delivered with device. The energy calibration is valid only for given values of other detector parameters as delivered in configuration file (especially threshold).

**Time-of-Arrival (ToA)** = number of periods of 40 MHz clock signal (25 ns step) from start of exposure till the event is registered by pixel (i.e. pulse in pixel crosses the threshold). The range is 409.6  $\mu$ s. Additional 16 bits are added in FPGA in readout electronics so that the total range is 26.8 seconds. The additional bits are usable only if the pixel hit rate is below maximal value (see  $f_p$  in table of Performance characteristics). The clock resets after 26.8 seconds but that does not limit the duration of scan.

**Fast-Time-of-Arrival (FToA)** = time difference between event detection and next clock signal measured with step of 1.5625 ns. Range is 4 bits. The combination of ToA and FToA gives precise time of event detection in nanoseconds using following formula:

$$\text{Time [ns]} = \text{ToA} * 25 - \text{FToA} * 1.5625$$

ToA and FTOA are combined together by software. If saved then ToA and FToA are stored as separate items.

### Measurement types:

**Frame type measurement** No data is sent out of device during the exposure time. All measured events are accumulated in counters of pixels. Event counter is incremented and ToT is integrated for all events. The measured data is read-out after end of exposure time for all pixels with nonzero content. No measurement can be performed during readout process.

**Pixel type measurement** Information about all hit pixels is read-out immediately and continuously during exposure time. If hit rate is below maximal value (see  $f_p$  in table of Performance characteristics) then there is virtually no deadtime.



Major modes and types of operation (rarely used combinations are shown with gray background):

Type	Mode	Range	Description
Frame (reading all pixels after end of exposure)	Event+iToT	10 bit + 14 bit	2 output frames per exposure: 1 <sup>st</sup> Events = Number of events in pixel, 2 <sup>nd</sup> iToT = total time over threshold for all events in pixel.
	iToT	14 bit	1 output frame: iToT = total time over threshold for all events in pixel.
	ToA	18 bit	1 output frame: ToA+FToA <sup>3</sup> = Time of Arrival of first event in pixel.
Pixel (reading only hit pixels continuously during exposure)	ToT+ToA	10 bit + 18 bit	4 numbers per pixel per event: Position, ToT, ToA and FToA.
	ToA	18 bit	3 numbers per pixel per event: Position, ToA and FToA.
	Only ToT	10 bit	2 number per pixel per event: Position and ToT.

## Vacuum Operation

Advacam detectors are vacuum compatible out of the box. Operate only with air pressure lower than 10<sup>-3</sup>Pa. Intended for dust free indoor use.

**Make sure to disconnect the device from power during pumping down or venting the vacuum chamber!**

## External Cooling

Temperature stabilization is strongly recommended for consistent results. Attaching a Peltier cooling or cooling plate at the back of the detector should serve the purpose. The temperature should be set to 22°C.

## Device description

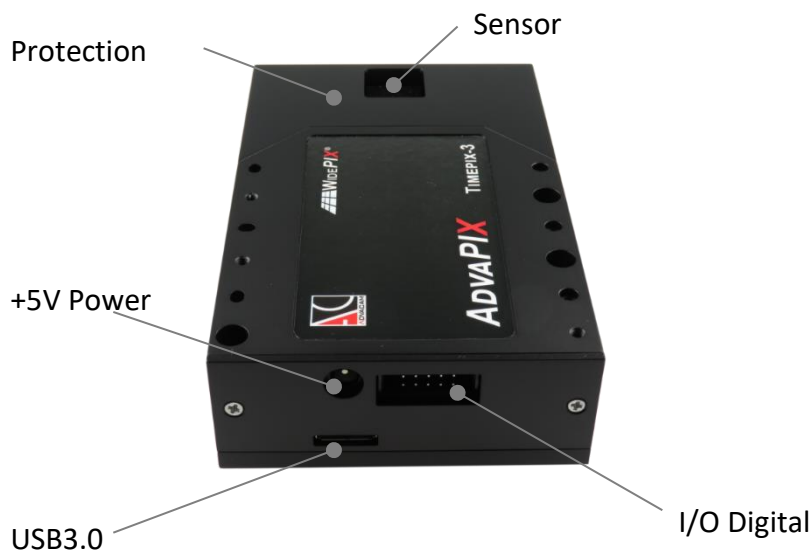

<sup>3</sup> ToA and FToA are combined together by software automatically. If saved, ToA and FToA are stored as separate items (for Pixel type measurement).



### +5VDC connector

Main power supply (via standard 5.5/2.1mm barrel connector). Connect after plugging USB connector.

### USB 3.0 connector

USB type micro B, Standard USB 3.0 Super-Speed.

### I/O Digital connector

Signals on I/O Digital connector are used for synchronization purposes. For details see Synchronization guide for TPX3. Input pins are **NOT** +5V compatible. Pin 2 (+5V) may be used for power of external circuitry. It is taken directly from +5VDC connector, protected by schottky diode (0.5A max) Pin directions (Input/output) are dependent on polarity of pin 9 (Dir Select).

Table for version APXMD3-Xxx170704

Pin	Name	Signal type	Pin	Name	Signal type
1	GND		2	+5V	
3	Resersved	CMOS 0-2.5V	4	Resersved	CMOS 0-2.5V
5	Resersved	CMOS 0-2.5V	6	Resersved	CMOS 0-2.5V
7	NC	-	8	Resersved	CMOS 0-3.3V
9	NC	-	10	Resersved	CMOS 0-3.3V

Table for version APXT3M-Xxx180119

Pin	Name	Signal type	Pin	Name	Signal type
1	GND		2	+5V	
3	CLK p	LVDS (2.5V)	4	CLK n	LVDS (2.5V)
5	E2	CMOS 0-2.5V	6	E1	CMOS 0-2.5V
7	Trigger Out	CMOS 0-2.5V	8	Trigger In	CMOS 0-2.5V
9	Dir select	CMOS 0-2.5V	10	GND	

Table for version APXT3M-Xxx200128 & APXT3M-Xxx201030

Pin	Name	Signal type	Pin	Name	Signal type
1	GND		2	+5V	
3	Master Disable	CMOS 0-2.5V/5V	4	CLK n	LVDS (2.5V)
5	CLK p	LVDS (2.5V)	6	T0/Sh-sel	CMOS 0-2.5V
7	Th/Sh p	LVDS (2.5V)	8	Th/Sh n	LVDS (2.5V)
9	Ready	CMOS 0-2.5V	10	T0/Sh-CMOS	CMOS 0-2.5V

### Certificates

AdvapiX TPX3 has been tested by certification authority (Electrotechnical testing institute EZÚ) according to following standards:

Standard number	Name
EN 61010-1:2010	Safety Requirements For Electrical Equipment For Measurement, Control, And Laboratory Use
EN 61326-1:13	Electrical Equipment For Measurement, Control And Laboratory Use - EMC Requirements





## Mechanical dimensions

Without protection cover

**Do not operate without protection cover!**

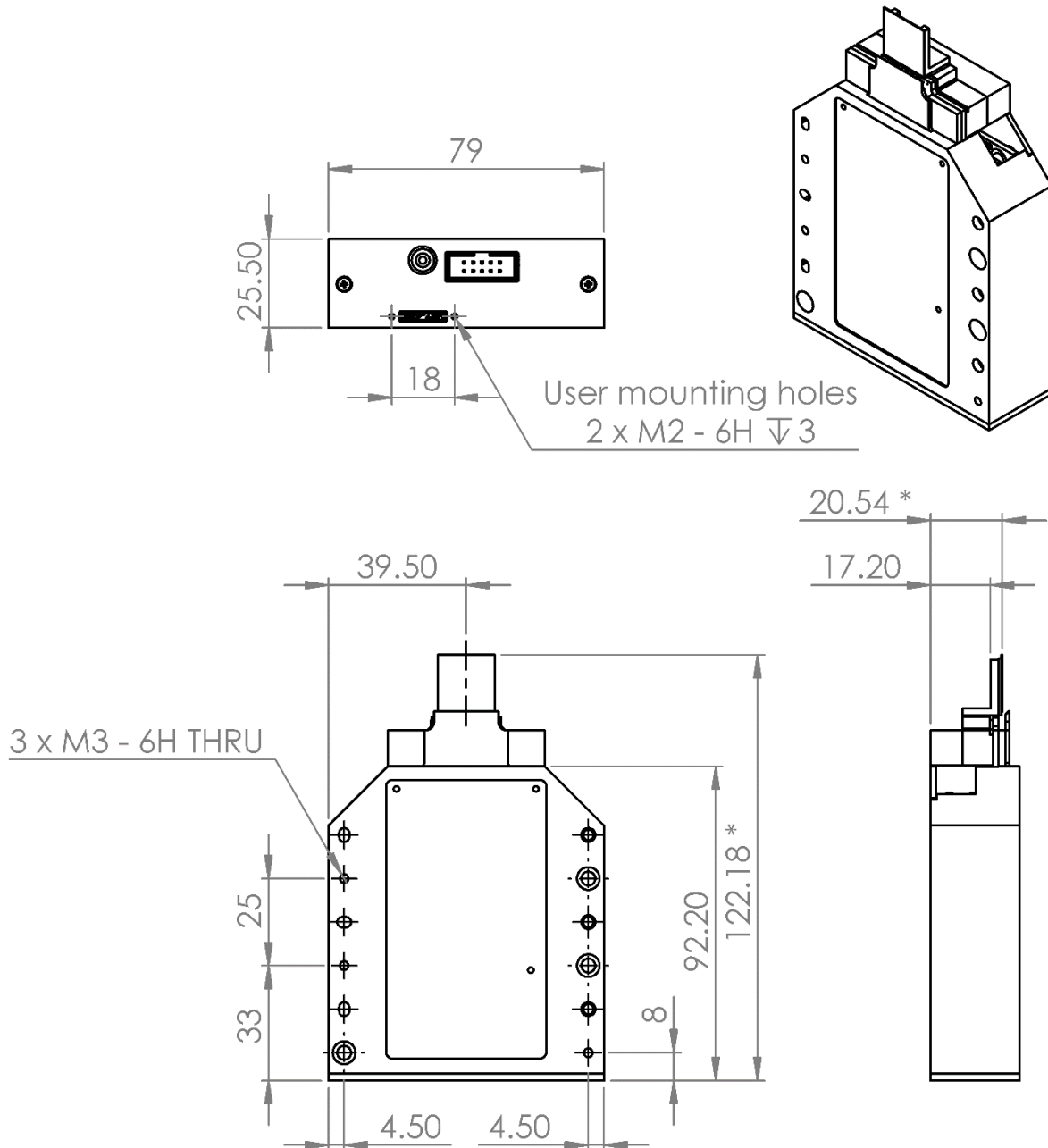

All dimensions are in mm.

\* Sensitive surface distance from bottom of the box is stated for 300  $\mu$ m sensor thickness.

Extreme care must be taken when removing protecting cover and handling the **ADVAPIX** TPX3 without the protecting cover. Warranty does not apply to mechanical damage of the sensor and wirebonds.

With protection cover

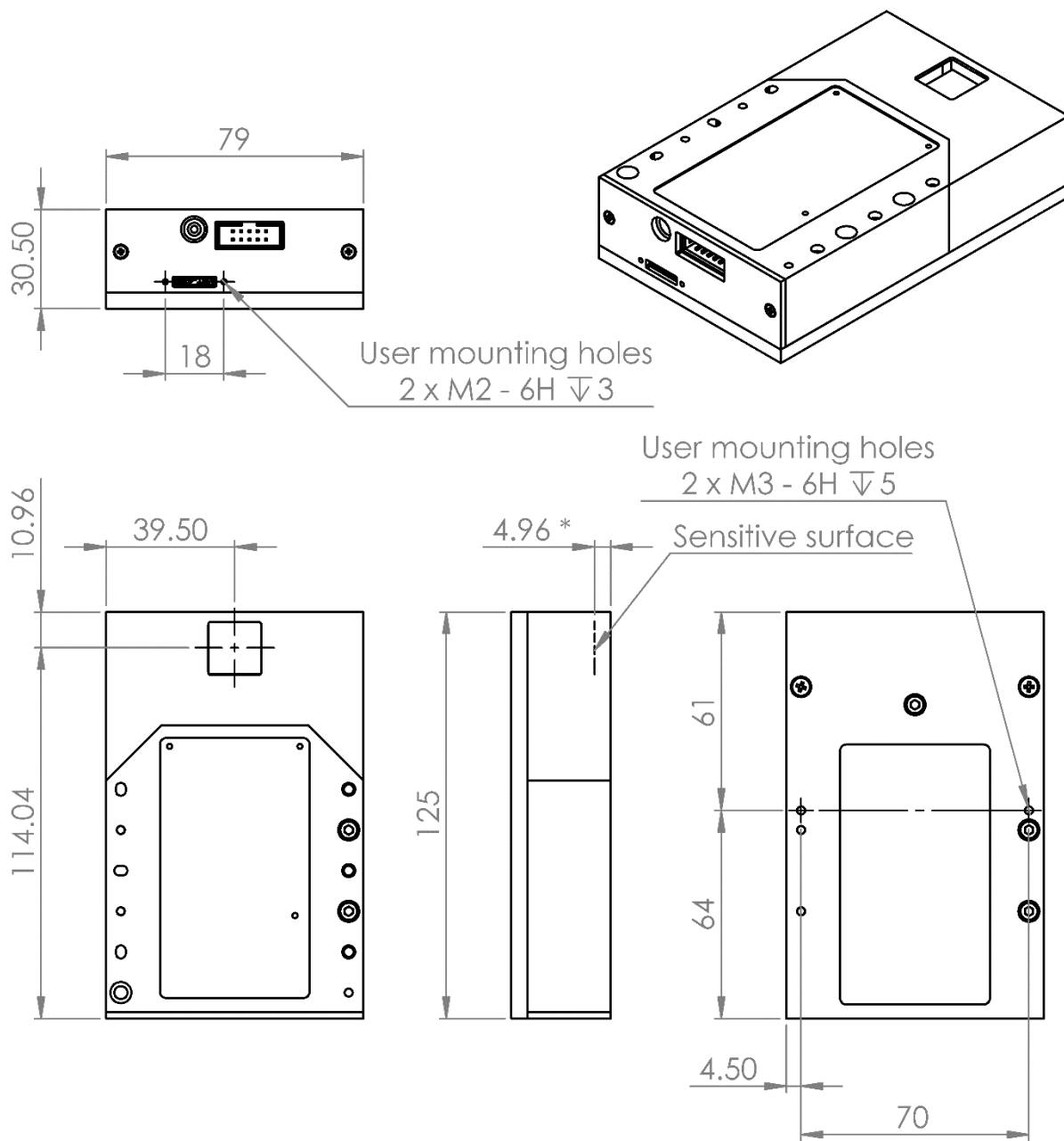

All dimensions are in mm.

\* Sensitive surface distance from top of the box is stated for 300  $\mu$ m sensor thickness.



## Model Number Codes

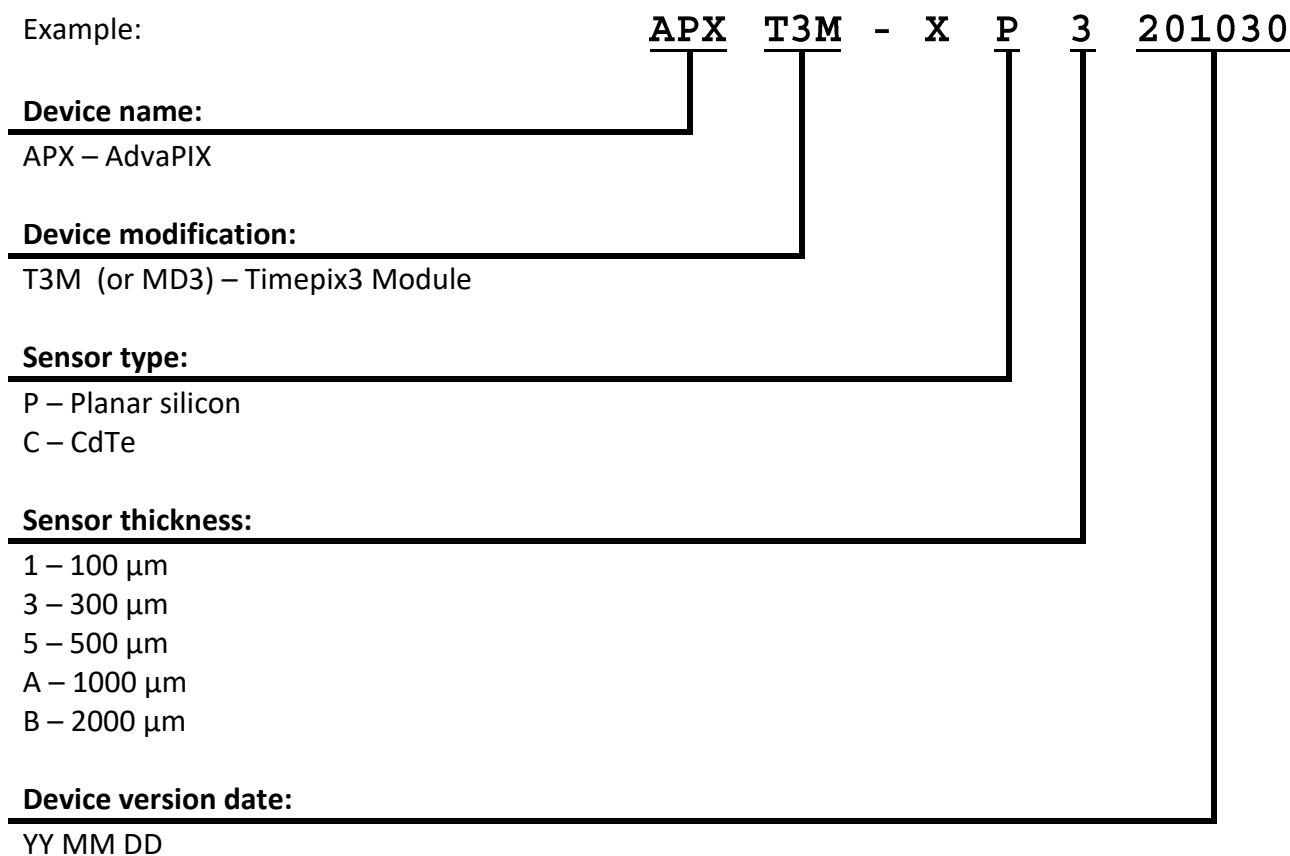

## Release history

Date	Changes
17/11/02	Model number codes added, datasheet version
18/02/08	Synchronization of 180119 version
19/04/16	Synchronization voltages corrected
19/07/22	Major revision: Added intended applications, description of modes and types, hit rate measurement.
19/07/29	EMC certificate numbers added
19/12/04	Sensor parameters, Detection efficiency
20/05/19	New version; Mechanical dimensions; Changed Synchronization
20/11/11	Mounting holes for USB
22/06/06	Vacuum compatibility; sensor parameters



# Warning

**Do not touch sensor surface!**

## Instructions for safe use

To avoid malfunction or damage to your **ADVAPIX** TPX3 please observe the following:

- Do not expose to water or moisture.
- Do not disassemble. Wire-bonding connection may be irreversibly damaged.
- Do not insert any object into the sensor window.
- Extreme care must be taken when removing the protecting cover or handling the **ADVAPIX** TPX3 without the protecting cover. Warranty does not apply to mechanical damage of the sensor and wirebonds
- The protection provided by this product may be impaired if it is used in a manner not described in this document

## Copyright

ADVACAM s.r.o.

U Pergamenky 1145/12

170 00 Praha

Czech Republic

Tel: +420 608 605 533

Email:

[sales@advacam.cz](mailto:sales@advacam.cz)

[www.advacam.com](http://www.advacam.com)

